

LXMGP5JF- Fibre optical splitter DOME Splice Enclosure

Linxcom offers this unique enclosure which is quick and easy to install and requires no specialist tooling. It can be placed in aerial, underground, wall-mounting, handhole mounting and duct-mounting applications. Based on an advanced formula, the plastic parts are made of injection-molded, high-strength engineering plastic PC by numerical control equipment, therefore effectively prevent products from aging caused by coldness, heat, oxygen and ultraviolet radiation

**Application**

- It can be used in straight-through and branching application
- It can be used in aerial, underground, direct buried, wall-mounting, hand hole and duct mounting application
- It can be mounted on a pole, wall or strand.

FEATURES:

- 5 general cable ports, could be suitable for connect different branch cable, including uncut cable.
- Unique sealing method obtained the national patent.
- It is suitable for aerial, pole-mounting, wall-mounting, pipe, manhole and direct buried installation method.
- IP protection degree is IP68.
- Chemical resistant

Specifications

Function:	Direct transmission, branching, passive optical fibre distribution
Splitter type:	Box splitter (TAP module)
Splitter installation position:	Fixed support bracket
Max OD ratio:	1:32
Adaptor type:	SC
Splice tray type:	7#
Splice tray quantity:	5pcs
Optional cables:	Φ3 round cable, figure 8 soft cable, self-support soft cable, 2 fibres pipe cables (Φ5~Φ7), 4.5×8.2 flat cable, Φ11.2 armour cable.
Standard accessory:	LXMDSE01X box 1 set, sealing gasket 1 set, splice tray 1 set, cable fixing device 1 set, pole-mounting kit 1 set, splice protective sleeve 1 set, nylon tie.
Optional accessory:	Grounding device 1 set, valve 1 set, aerial mounting kit 1 set, wall-mounting kit 1 set, SC adaptor, box type splitter.

Max capacity(F)	Suitable Dia of cable(mm)	Sealing structure	Weight/unit (Kg)	Size of CTN
120	Small port:Φ8~Φ17.5 Middle port:Φ4~Φ7 soft cable Big port:Φ10~Φ22	Dome type mechanical sealing		570X500X540 (4pcs)

INSTALLATION METHODS

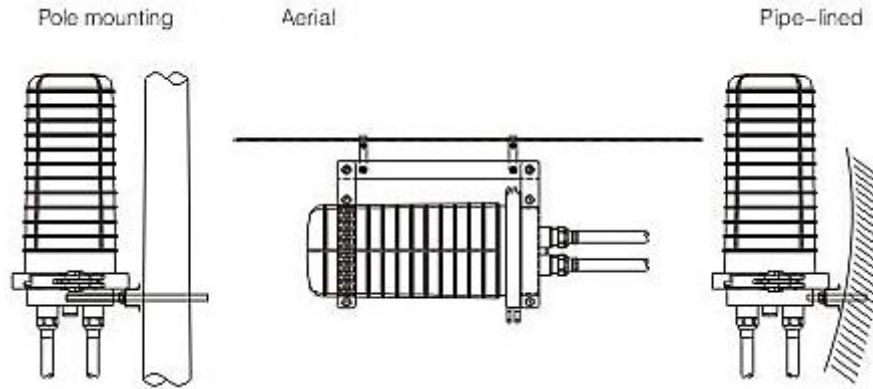

Remark: Please refer to the instruction manual for the detailed components

Standard Accessories

Box 1 set, sealing gasket 1set, splice tray 1 set, cable fixing device 1set, splice protective sleeve, nylon tie, spanner 1 piece, splice tray holder 1 piece, plastic plug 6 pieces, insulating tape 1 roll, pole mounting hoop 1 set.

Optional Accessories

Grounding device 1 set, valve 1 set, aerial hoop 1 set, protective tube.

PURCHASE TIP

Fibres/Tray	Max capacity(F)	Suitable Dia of cable(mm)	Sealing structure	Weight/unit (Kg)	Size of CTN
12	408(Single core)	Small port: $\Phi 6 \sim \Phi 17.5$ Big port: $\Phi 12 \sim \Phi 17.5$	Dome mechanical sealing	5.5~6.5	570X500X540 (4 pieces)